

LIRH LED Inset Threshold / End Light



تهران، بزرگراه شیخ فضل... نوری، خیابان سازمان آب، خیابان حاجی پور امیر، کوچه مهدی، پلاک ۱
No.1, Mahdi Alley, Haji Pour Amir St., Sazman Aab Ave., Sheikh Fazlollah Nouri Highway, Tehran, IRAN

Email info@tmb-co.com | فکس ۰۲۱۸۸۲۶۰۷۰۷ | تلفن ۰۲۱۸۷۷۴۰ | کدپستی ۱۴۵۴۶۴۳۶۸۵
Web www.tmb-co.com | Fax 98 218826 0707 | Tel 98 21 87740 | P.O Box 1454643685



- No optical adjustment after LED module or prism replacement
- Valve for watertightness test after overhaul
- Operating with any topology of CCRs designed in compliance with IEC or FAA requirements

** For monitored fixtures, isolation transformer max size: 200VA*

▶ PERFORMANCES

- The electronic is strong-built and highly resistant to shock and vibration
- Automatic adaptation to the frequency of the supply current
- A surge protection device is provided in the electronics as required by the FAA "Engineering Briefing No.67"
- Immediate detection of an internal fault
- 6.35 mm protrusion strongly reduces vibrations to aircrafts and to light itself, increasing its lifetime
- Dome smooth outer profile makes the light less sensitive to snowplough blades
- Bidirectional or unidirectional, 12" dia.
- Drop-forged dome and cast aluminium lower cover make the fitting sturdy, but lightweight too for ease handling in the field
- Light output practically not affected by heavy rainfall thanks to the shallow channel in front of the prism windows
- O-Ring placed outside the dome to avoid dirt deposits between light and base
- Protection degree: IP68
- Temperature range: -45°C to +55°C

▶ INSTALLATION

- Suitable for 12" dia. bases
- Specific tools available for easy and precise installation

▶ COMPLIANCES

- ICAO** Annex 14 - Volume I Fig. A2-3, A2-8
- EASA** CS-ADR-DSN, Book 1, Fig. U-7 and U-12
- FAA** L-850D(L) AC150/5345-46 and EB No.67
- EC** TS 61827
- NATO** STANAG 3316
- CAA** CAP 168
- IAAE** TP312

▶ APPLICATIONS

Threshold/Runway End for ICAO CAT I,II and III, FAA and military runways

▶ BENEFITS

- 60000 hours LED rated life at full intensity, but over 100000 hours in field operating conditions
- In new installation, LED lights mean lower loads, lower size of CCRs and transformers, thus low life cycle costs
- The light output is variable like a traditional halogen lamp, as indicated by the FAA "Engineering Briefing No.67"
- Colour emitted directly by LEDs : absence of coloured filters ensures no energy losses and no colour shifts
- Fully compatible with existing AFL infrastructure*
- Designed with simplicity allowing longer maintenance intervals and fewer spare parts
- No use of sealant to fix the prisms in the dome thanks to customized gaskets, making their replacement quick and easy



► **MAIN COMPONENTS OF THE LIGHT UNIT**

- 1 : Dome (Upper Cover)
- 2 : O-Ring for dome (internal)
- 3 : O-Ring for lower cover
- 4 : Prism Gasket
- 5 : Prism
- 6 : Prism holder gasket
- 7 : Mounting plate
- 8 : LED module with accessories
- 9 : Optical Lens
- 10 : Heat Sink
- 11 : Bracket
- 12 : Lower cover with electronic
- 13 : Valve for watertightness test
- 14 : Plug

*Refer to the relevant technical manual for the complete list of the available spare parts

► **PHOMETRIC PERFORMANCE**

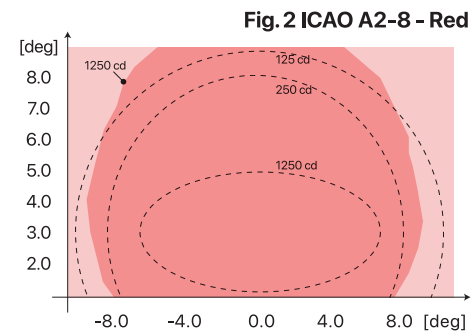
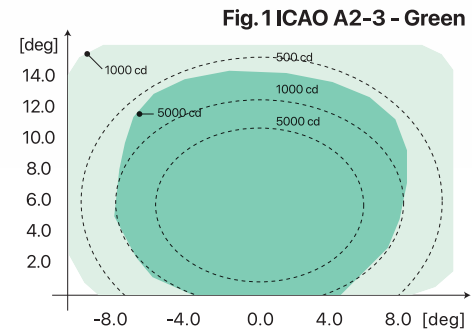

POWER CONSUMPTION		
Electrical System	1 Plug	2 Plugs
Unidirectional (w/o Arctic Kit)	-	-
Unidirectional (with Arctic Kit)	-	-
Bidirectional (w/o Arctic Kit)	54 VA	54 VA
Bidirectional (with Arctic Kit)	94 VA	134 VA

POWER FACTOR		
Input Step	2.8A	6.6A
Power Factor	0.96	0.98

SHIPPING WEIGHTS & VOLUMES		
	Light Unit	Shallow Base
Weight(kg)	7.3	7.3
Volume(m³)	0.022	0.022

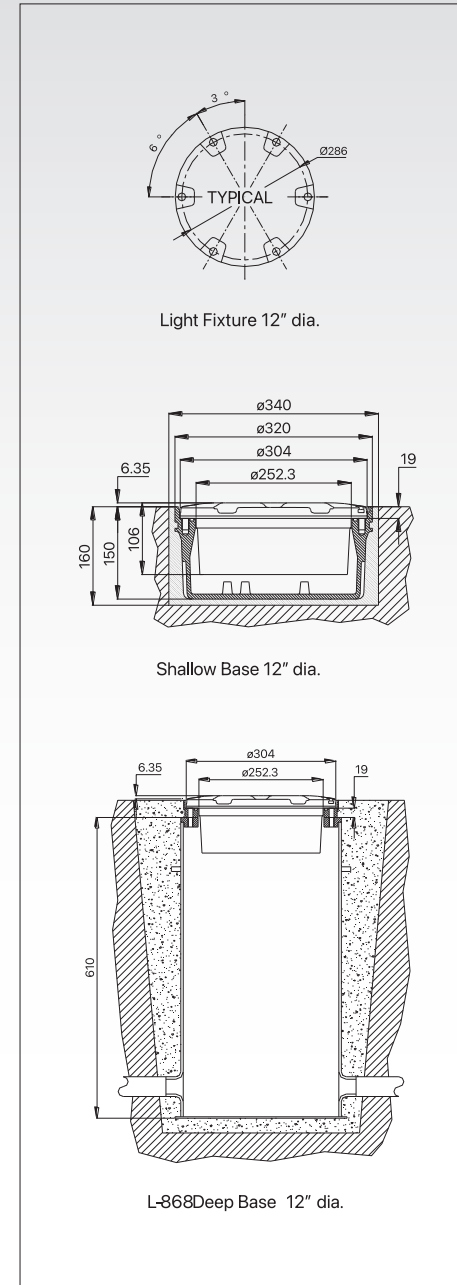

Basic P/N LIRH I GR L 2P M A

Compliance
I = ICAO

Colour (Side A)/(Side B)
G = Green
R = Red
M = Blank (Unidirectional Dome - FAA Only)*

Toe-in (Threshold Side)**
L = Right
R = Left
S = Straight

Electrical System
1P = One Plug
2P = Two Plugs

Monitoring:
O = Without Monitoring
M = With Monitoring

Arctic Kit
O = Without Arctic Kit
A = With Arctic Kit

* The aperture not finished "M" will be always on side "B"
** The beams aiming is not field adjustable

